



xunzel™

applied Solar and Wind Energy™

PRODUCT NOTE

XUNBOX™ Series

XUNBOX™ Series-XUNZEL XUNZEL Universal Battery Box

Product Overview

- Protects your battery from acid, gasoline, oil, rain, salt water, dirt, sunlight (UV), solvents and damages
- Keeps your battery safe, out of meteorological dangers, clean and dry
- Universal. Fits a wide range of batteries
- Heavy duty, Strong, Seamless, Plastic (corrosion-resistant)
- Reduces accident and short-circuit risk
- Snap-top lid with wiring-holes and gratings to guarantee a good ventilation preventing danger situations; with handles to make easy the transport and handling. Allows checking the battery, without having to undo all the installation
- Strap (1m x 35cm) for certain closing; it is UV-resistant, made of polypropylene and impervious to battery acid - it does not break down in acid as Nylon
- Ideal for all sort of applications, marine, RV, automotive and transport, outdoor, garden, telecom, traffic, agriculture and livestock...
- Colour: black
- Lightweight, only 116g
- Dimensions:
 - Inside 32.66cm x 16.92cm x 22.86cm
 - Outside 41.910cm x 24.638cm x 28.956cm (assembled)
- Includes a battery strap with hold-down brackets and stainless steel screws.



ALL INCLUDED



ALL INCLUDED

XUNBOX™ Series - XUNZEL

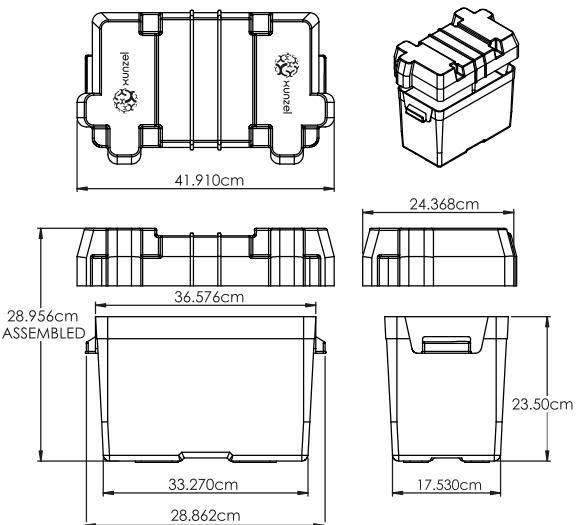

XU-2909215-AH

Industry Leading Technology for Off-Grid, Off-Shore and Backup Power Applications



info@xunzel.com
www.xunzel.com